

Manual strippers

MD 10 - 170
M 10 - 170

M 15 - 100
M 30 - 150

Manual benchtop stripping machines

Reger

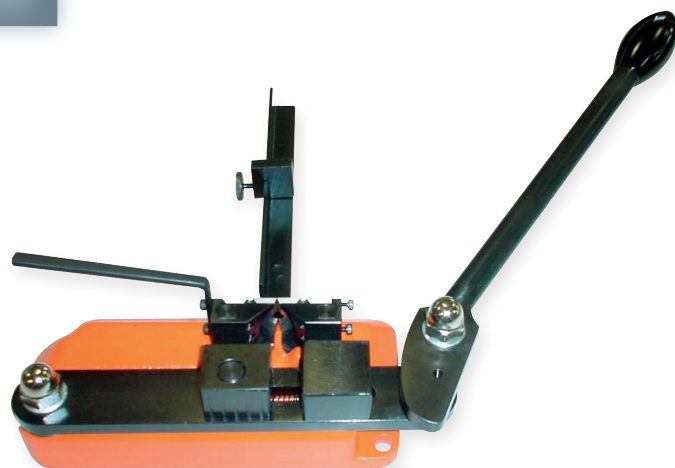

M15 - 100

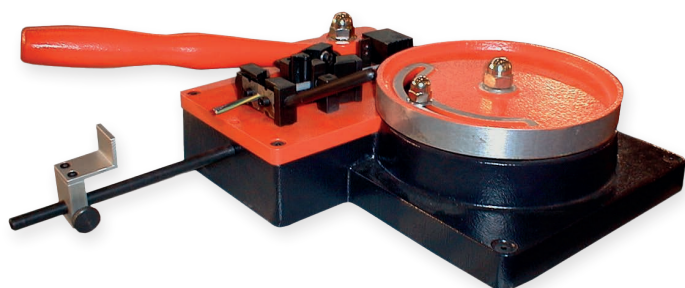

MD10 - 170 M10 - 170

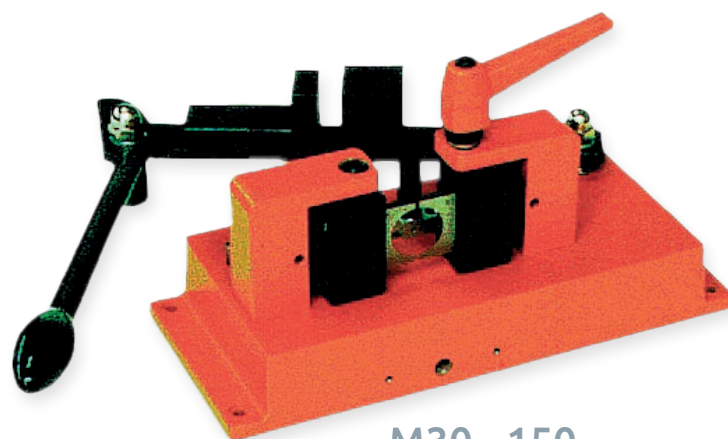

M30 - 150

VERSIONS

- **MD10 - 170**
Available 4-sided profiled blades from 2 to 10 mm in diameter with 0,5 mm increments
Internal stripping possible
- **M10 - 170**
Available 4-sided profiled blades from 2 to 10 mm diameter in 0,5 mm increments
- **M15 - 100**
Available 4-sided profiled blades from 2 to 13 mm in diameter with 0,5 mm increments
- **M30 - 150**
Available 2-sided profiled blades from 2 to 27 mm in diameter in 1 mm increments

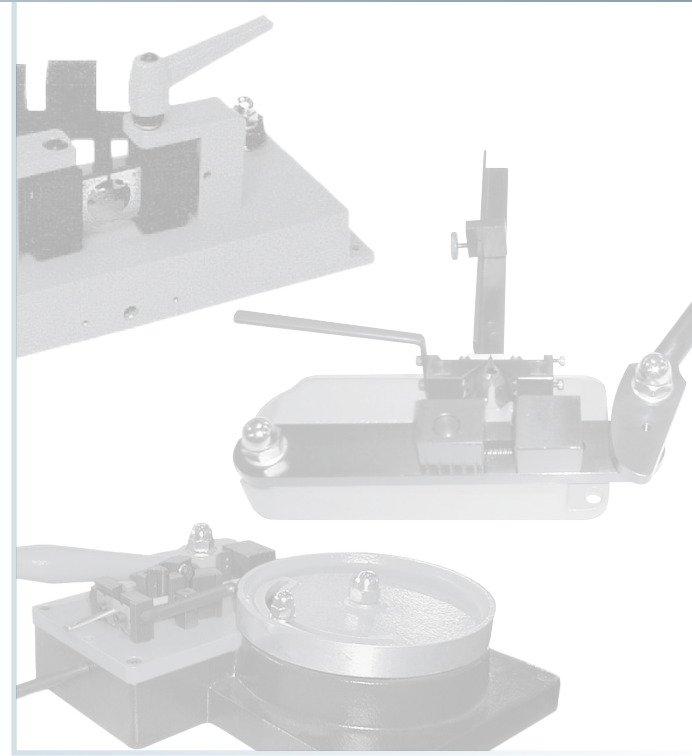

TECHNICAL SPECIFICATIONS

	MD10 - 170	M10 - 170	M15 - 100	M30 - 150
Cable diameter	max 10 mm	max 10 mm	max 15 mm	max 30 mm
Total sheathing length	max 170 mm	max 170 mm	max 100 mm	max 150 mm
Dimensions	250 x 340 x 100 mm	200 x 300 x 100 mm	200 x 300 x 100 mm	270 x 350 x 110 mm
Weight	3 Kg	3 Kg	3 Kg	3 Kg

CE Conformity: MD10 - 170 / M10 - 170 / M15 - 100 / M30 - 150 are fully compliant with CE regulations and EMC equipment guidelines for mechanical, electrical and electromagnetic compatibility.

Note: we recommend to send samples with the application requirements for a preliminary examination.